

**From a high flame to a low flame,  
flexible flame adjustment!  
Simple and handy Blast Chinese Range!**



(Metal Blast Burner)

(Jumbo Blast Burner)

Not only frying with a high flame but also stewing with a low flame – the flame is flexibly adjusted. With an easy one-touch ignition, the operation is very simple. There 2 types of burners to choose from. You can find a perfect one for your restaurant.

## Simple operation, easy one-touch ignition!

The operation panel is very simple. The pilot burner is ignited just by pressing the ignition button in the operation panel. You do not need to trouble with the conventional firing rod. The main burner can be ignited and extinguished just by turning ON/OFF of START/STOP switch. The flame can be ignited / extinguished quickly during cooking.



■ Operation Panel



■ START/STOP switch

## From a low flame to a high flame, **Patent Pending** wide range of flame adjustment is possible!

20,000kcal/h type burner can create a lowest flame at 3,500kcal/h. It can handle a wide range of cooking styles, from frying by a high flame to stewing a small amount by a low flame. The flame adjustment is simple by lever operation.

■ The lever is divided to upper part and lower part, enabling to control by hand or knee.



## Metal Blast Burner and Jumbo Blast Burner to choose from!

Blast Chinese Range has 2 specs; Metal Blast Burner integrated spec and Jumbo Blast Burner integrated spec. You can choose one depending on your menu structure or preference.

### Metal Blast Burner

This is a highly efficient burner that intensively heats the center of the bottom of pan by high-temperature concentrated heating. The high flame is concentrated at the center, which is perfect for frying. **It is suitable for Cantonese food and mass cooking with a big pan.** It is also suitable for stewing by a low flame.



■ Maximum combustion



■ Minimum combustion

**Quieter!**  
Excellent quietness is realized even at a maximum combustion!

■ Standard range of heating power controlled by lever operation

Model	MIN~MAX(kcal/h)
DRX-M20B	3,500~20,000
DRX-M25B	4,000~25,000
DRX-M35B	5,000~35,000

### Jumbo Blast Burner

This is a handy burner that heats a large area of the pan. It is an all-around burner that **can be used in various genres such as ramen restaurants, Sichuan and Beijing cuisine as well as stewing.**



■ Maximum combustion



■ Minimum combustion

■ Standard range of heating power controlled by lever operation

Model	MIN~MAX(kcal/h)
DRX-J25B	4,500~25,000
DRX-J30B	5,500~30,000

## ● Reliable safety devices

Pilot burner is programmed to keep ignited and shows errors in case of ignition failure or accidental fire. Pilot safety shut off device is equipped. So that, gas is shut off automatically if the flame of pilot burner goes off. These devices improve the safety of the product.

## ● Easy to clean top plate because corner R finish is performed

## Metal Blast Burner integrated spec

Metal Blast Burner that intensively heats the center of the bottom of the pan at a high temperature has 3 types of heating powers; 20,000kcal/h, 25,000kcal/h and 35,000kcal/h. Frying stove (stove diameter;  $\phi 300$ ,  $\phi 330$ ) and Fried Noodle stove (stove diameter;  $\phi 390$ ) can be combined with the burner.



■ Super durable cast iron stove frame

### DRX-M20B

$\phi 300$  Frying stove

List price **¥558,000**  
(tax-excluded)

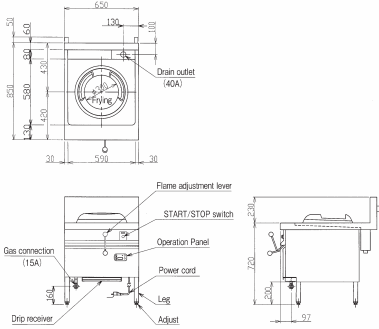

**NEW**



### DRX-M25B

$\phi 330$  Frying stove

List price **¥578,000**  
(tax-excluded)

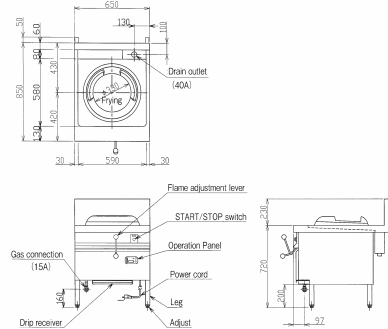

**NEW**



### DRX-M35B

$\phi 390$  Fried Noodle stove

List price **¥618,000**  
(tax-excluded)

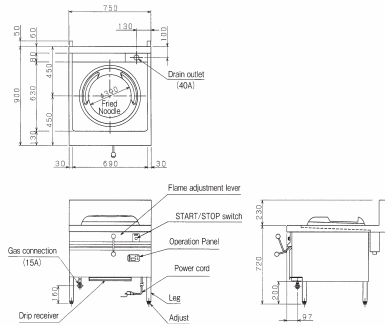

**NEW**



## Jumbo Blast Burner integrated spec

Jumbo Blast Burner with an established reputation for the powerful heating has 2 types of Frying stove (stove diameter;  $\phi 300$ ,  $\phi 330$ ) can be combined with the burner.



■ Super durable cast iron stove frame

### DRX-J25B

$\phi 300$  Frying stove

List price **¥578,000**  
(tax-excluded)

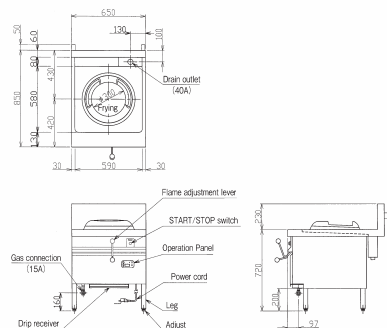

**Model Change**



### DRX-J30B

$\phi 330$  Frying stove

List price **¥598,000**  
(tax-excluded)

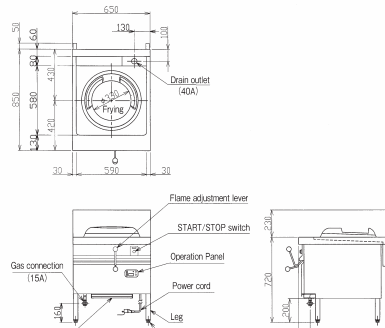

**Model Change**



### DRX Blast Chinese Range Specifications Table

Burner	Model	External dimensions (mm)				Gas consumption		Gas connection	Drain outlet	Rated voltage (50/60Hz)	Power consumption (50/60Hz)	Power cord	Weight (kg)	Use
		Width	Depth	Height	Back	Town gas	LP gas							
Metal Blast	★ DRX-M20B	650	850	720	230	23.3kW (20,000kcal/h)	23.3kW (1.67kg/h)	15A	40A	1 $\phi$ 100V	47W	2m with plug (ground adaptor)	115	Frying
	DRX-M25B	650	850	720	230	29.1kW (25,000kcal/h)	29.1kW (2.08kg/h)	15A	40A	1 $\phi$ 100V	50W		125	Frying
	★ DRX-M35B	750	900	720	230	40.7kW (35,000kcal/h)	40.7kW (2.92kg/h)	15A	40A	1 $\phi$ 100V	54W		140	Fried Noodle
Jumbo Blast	DRX-J25B	650	850	720	230	29.1kW (25,000kcal/h)	29.1kW (2.08kg/h)	15A	40A	1 $\phi$ 100V	43W	Ⓢ	110	Frying
	DRX-J30B	650	850	720	230	34.9kW (30,000kcal/h)	34.9kW (2.50kg/h)	15A	40A	1 $\phi$ 100V	44W		120	Frying

Delivery date of the models with ★mark is about 2 weeks after receipt of order. ■Please see the back cover for the diameter of the pans usable.